

CSIR-UGC (NET) Physical Science

Previous Year Solved Paper (Booklet Code -C)

Duration : 180 minutes

Maximum Marks : 200

Read the following instructions carefully.

The question paper is divided in three parts :

Part 'A' : This part contains twenty (20) objective type questions. The candidates shall be required to answer any 15 questions. Each question shall be of two marks. The total marks allocated to this section shall be 30 out of 200.

Part 'B' : This part contains twenty five (25) objective type questions. The candidate shall be required to answer any 20 questions. Each question shall be of 3.5 marks. The total marks allocated to this section shall be 70 out of 200.

Part 'C' : This part contains thirty (30) objective type questions. A candidate shall be required to answer any 20 questions. Each question shall be of 5 marks. The total marks allocated to this section shall be 100 out of 200.

» There will be negative marking for all Part @ 25% for each wrong answer.

PART 'A'

1.

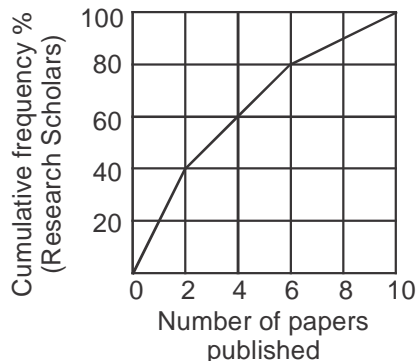

The graph shows cumulative frequency % of research scholars and the number of papers published by them. What of the following statements is true ?

- (1) Majority of the scholars published more than 4 papers.
- (2) 60% of the scholars published at least 2 papers.
- (3) 80% of the scholars published at least 6 papers.
- (4) 30% of the scholars have not published any paper.

2. A tells only lies on Monday, Tuesday and Wednesday and speaks only the truth for the rest of the week. B tells only lies on Thursday, Friday and Saturday and speaks only the truth for the rest of the week. If today both of them state that they have lied yesterday, what day is it today ?

- | | |
|------------|--------------|
| (1) Monday | (2) Thursday |
| (3) Sunday | (4) Tuesday |

3. A fair die was thrown three times and the outcome was repeatedly six. If the die is thrown again what is the probability of getting six ?

- | | |
|--------------|-------------|
| (1) $1/6$ | (2) $1/216$ |
| (3) $1/1296$ | (4) 1 |

4. A bread contains 40% (by volume) edible matter and the remaining space is filled with air. If the density of edible matter is 2 g/cc, what will be the bulk density of the bread (in g/cc) ?

- | | |
|---------|---------|
| (1) 0.4 | (2) 0.8 |
| (3) 1.2 | (4) 1.6 |

5. A board has 8 rows and 8 columns. A move is defined as two steps along a column followed by one step along a row or vice-versa. What is the minimum number of moves needed to go from one corner to the diagonally opposite corner ?

- | | |
|-------|-------|
| (1) 5 | (2) 6 |
| (3) 7 | (4) 9 |

6. A job interview is taking place with 21 male and 17 female candidates. Candidates are called randomly. What is the minimum number of candidates to be called to ensure that at least two males or two females have been interviewed ?

- | | |
|--------|--------|
| (1) 17 | (2) 2 |
| (3) 3 | (4) 21 |

7. Which is the odd one out based on a divisibility test ?
154, 286, 363, 474, 572, 682
- (1) 474 (2) 572
(3) 682 (4) 154
8. An ant starts at the origin and moves along the y-axis and covers a distance l . This is its first stage in its journey. Every subsequent stage requires the ant to turn right and move a distance which is half of its previous stage. What would be its coordinates at the end of its 5th stage ?
- (1) $\left(\frac{3l}{8}, \frac{13l}{16}\right)$ (2) $\left(\frac{13l}{16}, \frac{3l}{8}\right)$
(3) $\left(\frac{13l}{8}, \frac{3l}{16}\right)$ (4) $\left(\frac{13l}{16}, \frac{13l}{8}\right)$
9. In a group of siblings there are seven sisters, and each sister has one brother. How many siblings are there in total ?
- (1) 15 (2) 14
(3) 8 (4) 7
10. What is the average value of y for the range of x shown in the following plot ?

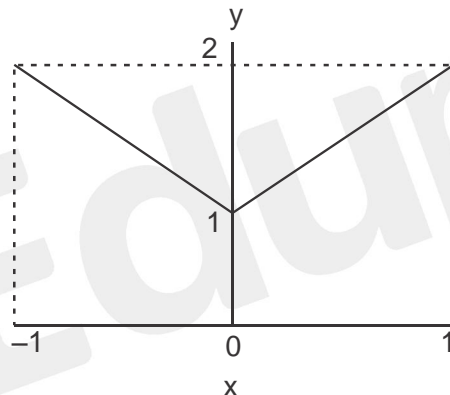

- (1) 0 (2) 1
(3) 1.5 (4) 2
11. In $\triangle ABC$, $AB = AC$ and $\angle BAC = 90^\circ$; $EF \parallel AB$ and $DF \parallel AC$.
The total area of the shaded region is

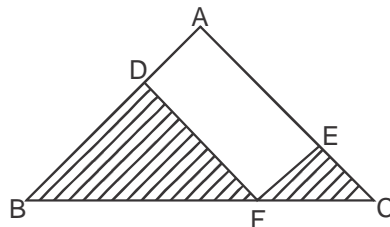

- (1) $AF^2/2$ (2) AF^2
(3) $BC^2/2$ (4) BC^2

12. Consider a circle of radius r . Fit the largest possible square inside it and the largest possible circle inside the square. What is the radius of the innermost circle ?
- (1) $r/\sqrt{2}$ (2) $\pi r/\sqrt{2}$
 (3) $\frac{r}{2\pi\sqrt{2}}$ (4) $r/2$
13. In how many ways can you place N coins on a board with N rows and N columns such that every row and every column contains exactly one coin ?
- (1) N (2) $N(N-1)(N-2) \dots 2 \times 1$
 (3) N^2 (4) N^N
14. A 100 m long train crosses a 200 m long and 20 m wide bridge in 20 seconds. What is the speed of the train in km/hr ?
- (1) 45 (2) 36
 (3) 54 (4) 57.6
15. My birthday is in January. What would be a sufficient number of questions with 'Yes/No' answers that will enable one to find my birth date ?
- (1) 6 (2) 3
 (3) 5 (4) 2
16. A square is drawn with one of its sides as the hypotenuse of a right angled triangle as shown in the figure. What is the area of the shaded circle ?

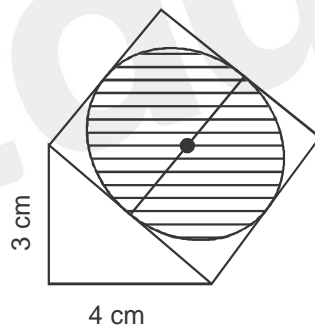

- (1) $\frac{25\pi}{1} \text{ cm}^2$ (2) $\frac{25\pi}{2} \text{ cm}^2$
 (3) $\frac{25\pi}{3} \text{ cm}^2$ (4) $\frac{25\pi}{4} \text{ cm}^2$
17. What should be added to the product of the two numbers 983713 and 983719 to make it a perfect square ?
- (1) 9 (2) 13
 (3) 19 (4) 27

18. Two identical wheels B and C move on the periphery of circle A. Both start at the same point on A and return to it, B moving inside A and C outside it. Which is the correct statement ?

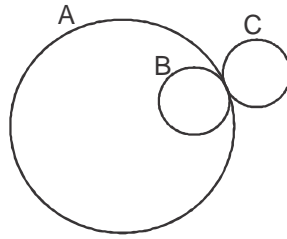

- (1) B wears out π times C. (2) C wears out π times B.
 (3) B and C wear out about equally. (4) C wears out two times B.
19. Which of the following is the odd one out ?
- (1) Isosceles triangle (2) Square
 (3) Regular hexagon (4) Rectangle
20. Find the missing word: A, AB, _____, ABBABAAB
- (1) AABB (2) ABAB
 (3) ABBA (4) BAAB

PART 'B'

21. The function $y(x)$ satisfies the differential equation $x \frac{dy}{dx} + 2y = \frac{\cos \pi x}{x}$. If $y(1) = 1$, the value of $y(2)$ is
- (1) π (2) 1
 (3) $1/2$ (4) $1/4$
22. The integral $\oint_{\Gamma} \frac{ze^{i\pi z/2}}{z^2 - 1} dz$ along the closed contour Γ shown in the figure is

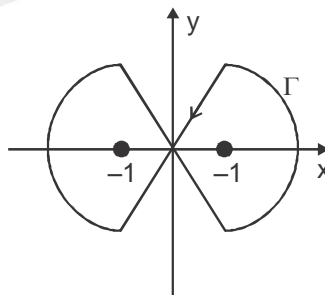

- (1) 0 (2) 2π
 (3) -2π (4) $4\pi i$
23. Let $u(x, y) = e^{ax} \cos(by)$ be the real part of a function $f(z) = u(x, y) + iv(x, y)$ of the complex variable $z = x + iy$, where a, b are real constants and $a \neq 0$. The function $f(z)$ is complex analytic everywhere in the complex plane if and only if
- (1) $b = 0$ (2) $b = \pm a$
 (3) $b = \pm 2\pi a$ (4) $b = a \pm 2\pi$

24. Which of the following cannot be the eigenvalues of a real 3×3 matrix ?
- (1) $2i, 0, -2i$ (2) $1, 1, 1$
 (3) $e^{i\theta}, e^{-i\theta}, 1$ (4) $i, 1, 0$
25. A ball weighing 100 gm, released from a height of 5 m, bounces perfectly elastically off a plate. The collision time between the ball and the plate is 0.5 s. The average force on the plate is approximately
- (1) 3 N (2) 2 N
 (3) 5 N (4) 4 N
26. A solid vertical rod, of length L and cross-sectional area A , is made of a material of Young's modulus Y . The rod is loaded with a mass M , and, as a result, extends by a small amount ΔL in the equilibrium condition. The mass is then suddenly reduced to $M/2$. As a result the rod will undergo longitudinal oscillation with an angular frequency
- (1) $\sqrt{2YA/ML}$ (2) $\sqrt{YA/ML}$
 (3) $\sqrt{2YA/M\Delta L}$ (4) $\sqrt{YA/M\Delta L}$

27. The Hamiltonian for a system described by the generalized coordinate x and generalized momentum p is

$$H = \alpha x^2 p + \frac{p^2}{2(1+2\beta x)} + \frac{1}{2} \omega^2 x^2$$

where α , β and ω are constants. The corresponding Lagrangian is

- (1) $\frac{1}{2}(\dot{x} - \alpha x^2)^2(1+2\beta x) - \frac{1}{2}\omega^2 x^2$ (2) $\frac{1}{2(1+2\beta x)}\dot{x}^2 - \frac{1}{2}\omega^2 x^2 - \alpha x^2 \dot{x}$
 (3) $\frac{1}{2}(\dot{x}^2 - \alpha^2 x)^2(1+2\beta x) - \frac{1}{2}\omega^2 x^2$ (4) $\frac{1}{2(1+2\beta x)}\dot{x}^2 - \frac{1}{2}\omega^2 x^2 + \alpha x^2 \dot{x}$
28. An inertial observer sees two events E_1 and E_2 happening at the same location but $6\mu\text{s}$ apart in time. Another observer moving with a constant velocity v (with respect to the first one) sees the same events to be $9\mu\text{s}$ apart. The spatial distance between the events, as measured by the second observer, is approximately
- (1) 300 m (2) 1000 m
 (3) 2000 m (4) 2700 m

29. The random variable $x(-\infty < x < \infty)$ is distributed according to the normal distribution

$$P(x) = \frac{1}{\sqrt{2\pi\sigma^2}} e^{-\frac{x^2}{2\sigma^2}}. \text{ The probability density of the random variable } y = x^2 \text{ is}$$

- (1) $\frac{1}{\sqrt{2\pi\sigma^2 y}} e^{-y/2\sigma^2}, 0 \leq y < \infty$ (2) $\frac{1}{2\sqrt{2\pi\sigma^2 y}} e^{-y/2\sigma^2}, 0 \leq y < \infty$
 (3) $\frac{1}{\sqrt{2\sigma^2}} e^{-y/2\sigma^2}, 0 \leq y < \infty$ (4) $\frac{1}{\sqrt{2\pi\sigma^2 y}} e^{-y/\sigma^2}, 0 \leq y < \infty$

30. The two vectors $\begin{pmatrix} a \\ 0 \end{pmatrix}$ and $\begin{pmatrix} b \\ c \end{pmatrix}$ are orthonormal if

- (1) $a = \pm 1, b = \pm 1/\sqrt{2}, c = \pm 1/\sqrt{2}$ (2) $a = \pm 1, b = \pm 1, c = 0$
 (3) $a = \pm 1, b = 0, c = \pm 1$ (4) $a = \pm 1, b = \pm 1/2, c = 1/2$

31. Two long hollow co-axial conducting cylinders of radii R_1 and R_2 ($R_1 < R_2$) are placed in vacuum as shown in the figure below.

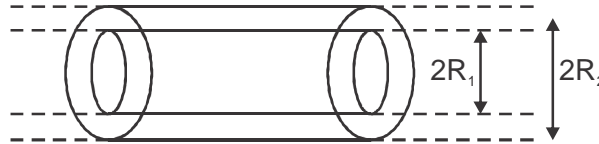

The inner cylinder carries a charge $+\lambda$ per unit length and the outer cylinder carries a charge $-\lambda$ per unit length. The electrostatic energy per unit length of this system is

- (1) $\frac{\lambda^2}{\pi \epsilon_0} \ln(R_2/R_1)$ (2) $\frac{\lambda^2}{4\pi \epsilon_0} \ln(R_2^2/R_1^2)$
 (3) $\frac{\lambda^2}{4\pi \epsilon_0} \ln(R_2/R_1)$ (4) $\frac{\lambda^2}{2\pi \epsilon_0} \ln(R_2/R_1)$

32. A set of N concentric circular loops of wire, each carrying a steady current I in the same direction, is arranged in a plane. The radius of the first loop is $r_1 = a$ and the radius of the n^{th} loop is given by $r_n = n r_{n-1}$. The magnitude B of the magnetic field at the centre of the circles in the limit $N \rightarrow \infty$, is

- (1) $\mu_0 I (e^2 - 1)/4\pi a$ (2) $\mu_0 I (e - 1)/\pi a$
 (3) $\mu_0 I (e^2 - 1)/8a$ (4) $\mu_0 I (e - 1)/2a$

33. An electromagnetic wave (of wavelength λ_0 in free space) travels through an absorbing medium with dielectric permittivity given by $\epsilon = \epsilon_R + i\epsilon_t$ where $\frac{\epsilon_t}{\epsilon_R} = \sqrt{3}$. The skin depth is $\frac{\lambda_0}{4\pi}$, the ratio of the amplitude of electric field E to that of the magnetic field B , in the medium (in ohms) is

- (1) 120π (2) 377
 (3) $30\sqrt{2}\pi$ (4) 30π

34. The vector potential $\vec{A} = ke^{-at} r\hat{r}$ (where a and k are constants) corresponding to an electromagnetic field is changed to $\vec{A}' = -ke^{-at} r\hat{r}$. This will be a gauge transformation if the corresponding change $\phi' - \phi$ in the scalar potential is

- (1) $akr^2 e^{-at}$ (2) $2akr^2 e^{-at}$
 (3) $-akr^2 e^{-at}$ (4) $-2akr^2 e^{-at}$

35. If the root-mean-squared momentum of a particle in the ground state of a one-dimensional simple harmonic potential is p_0 , then its root-mean-squared momentum in the first excited state is

- (1) $p_0\sqrt{2}$ (2) $p_0\sqrt{3}$
 (3) $p_0\sqrt{2/3}$ (4) $p_0\sqrt{3/2}$

36. Consider a potential barrier A of height V_0 and width b , and another potential barrier B of height $2V_0$ and the same width b . The ratio T_A/T_B of tunnelling probabilities T_A and T_B , through barriers A and B respectively, for a particle of energy $V_0/100$, is best approximated by

- (1) $\exp\left[(\sqrt{1.99} - \sqrt{0.99})\sqrt{8mV_0b^2/\hbar^2}\right]$ (2) $\exp\left[(\sqrt{1.98} - \sqrt{0.98})\sqrt{8mV_0b^2/\hbar^2}\right]$
 (3) $\exp\left[(\sqrt{2.99} - \sqrt{0.99})\sqrt{8mV_0b^2/\hbar^2}\right]$ (4) $\exp\left[(\sqrt{2.98} - \sqrt{0.98})\sqrt{8mV_0b^2/\hbar^2}\right]$

37. A constant perturbation H' is applied to a system for time Δt (where $H'\Delta t \ll \hbar$) leading to a transition from a state with energy E_i to another with energy E_f . If the time of application is doubled, the probability of transition will be

- (1) unchanged (2) doubled
 (3) quadrupled (4) halved

38. The gain of the circuit given below is $-\frac{1}{\omega RC}$

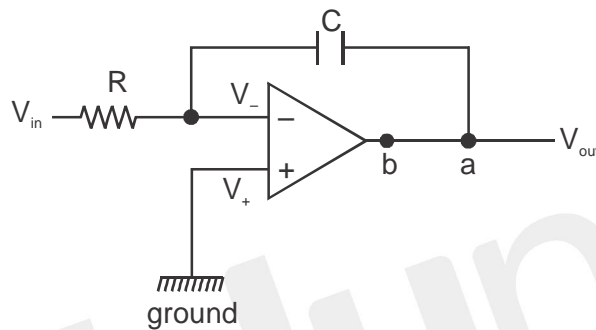

The modification in the circuit required to introduce a de feedback is to add a resistor

- (1) between a and b.
 (2) between positive terminal of the op-amp and ground.
 (3) in series with C.
 (4) parallel to C.

39. A 2×4 decoder with an enable input can function as a

- (1) 4×1 multiplexer (2) 1×4 demultiplexer
 (3) 4×2 encoder (4) 4×2 priority encoder

40. The experimentally measured value of the variables x and y are 2.00 ± 0.05 and 3.00 ± 0.02 , respectively. What is the error in the calculated value of $z = 3y - 2x$ from the measurements ?

- (1) 0.12 (2) 0.05
 (3) 0.03 (4) 0.07

41. The thermodynamic function

$$G(T, P, N) = U - TS + PV$$

is given in terms of the internal energy U , temperature T , entropy S , pressure P , volume V and the number of particles N . Which of the following relations is true? (In the following μ is the

chemical potential).

$$(1) \quad S = -\left. \frac{\partial G}{\partial T} \right|_{N,P}$$

$$(2) \quad S = \left. \frac{\partial G}{\partial T} \right|_{N,P}$$

$$(3) \quad V = -\left. \frac{\partial G}{\partial P} \right|_{N,T}$$

$$(4) \quad \mu = -\left. \frac{\partial G}{\partial N} \right|_{P,T}$$

42. A box, separated by a movable wall, has two compartments filled by a monoatomic gas of $\frac{C_p}{C_v} = \gamma$. Initially the volumes of the two compartments are equal, but the pressures are $3P_0$ and P_0 , respectively. When the wall is allowed to move, the final pressures in the two compartments become equal. The final pressure is

$$(1) \quad \left(\frac{2}{3}\right)^\gamma P_0$$

$$(2) \quad 3\left(\frac{2}{3}\right)^\gamma P_0$$

$$(3) \quad \frac{1}{2}(1+3^{1/\gamma})^\gamma P_0$$

$$(4) \quad \left(\frac{3^{2/\gamma}}{1+3^{1/\gamma}}\right)^\gamma P_0$$

43. A gas of photons inside a cavity of volume V is in equilibrium at temperature T . If the temperature of the cavity is changed to $2T$, the radiation pressure will change by a factor of

$$(1) \quad 2$$

$$(2) \quad 16$$

$$(3) \quad 8$$

$$(4) \quad 4$$

44. In a thermodynamic system in equilibrium each molecule can exist in three possible states with probabilities $1/2$, $1/3$ and $1/6$ respectively. The entropy per molecule is

$$(1) \quad k_B \ln 3$$

$$(2) \quad \frac{1}{2} k_B \ln 2 + \frac{2}{3} k_B \ln 3$$

$$(3) \quad \frac{2}{3} k_B \ln 2 + \frac{1}{2} k_B \ln 3$$

$$(4) \quad \frac{1}{2} k_B \ln 2 + \frac{1}{6} k_B \ln 3$$

45. In the n-channel JFET shown in figure below, $V_i = -2$ V, $C = 10$ pF, $V_{DD} = +16$ V, and $R_D = 2$ k Ω .

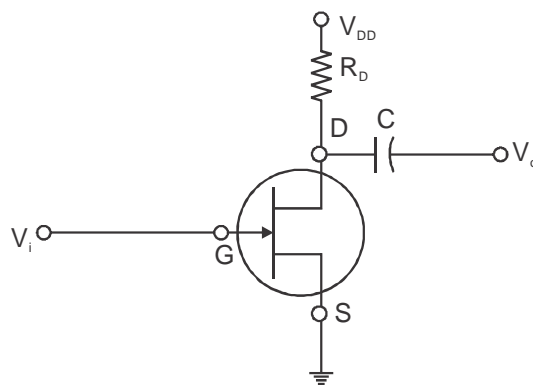

If the drain D-source S saturation current I_{DSS} is 10 mA and the pinch-off voltage V_p is -8 V, then the voltage across points D and S is

$$(1) \quad 11.125 \text{ V}$$

$$(2) \quad 10.375 \text{ V}$$

$$(3) \quad 5.75 \text{ V}$$

$$(4) \quad 4.75 \text{ V}$$

PART 'C'

46. The energy of a one-dimensional system, governed by the Lagrangian

$$L = \frac{1}{2} m \dot{x}^2 - \frac{1}{2} k x^{2n}$$

where k and n are two positive constants, is E_0 . The time period of oscillation τ satisfies

- (1) $\tau \propto k^{-1/n}$ (2) $\tau \propto k^{-\frac{1}{2n}} E_0^{\frac{1-n}{2n}}$
 (3) $\tau \propto k^{\frac{1}{2n}} E_0^{\frac{n-2}{2n}}$ (4) $\tau \propto k^{\frac{1}{n}} E_0^{\frac{1+n}{2n}}$

47. An electron is decelerated at a constant rate starting from an initial velocity u (where $u \ll c$) to $u/2$ during which it travels a distance s . The amount of energy lost to radiation is

- (1) $\frac{\mu_0 e^2 u^2}{3\pi m c^2 s}$ (2) $\frac{\mu_0 e^2 u^2}{6\pi m c^2 s}$
 (3) $\frac{\mu_0 e^2 u}{8\pi m c s}$ (4) $\frac{\mu_0 e^2 u}{16\pi m c s}$

48. The figure below describes the arrangement of slits and screens in a Young's double slit experiment. The width of the slit in S_1 is a and the slits in S_2 are of negligible width.

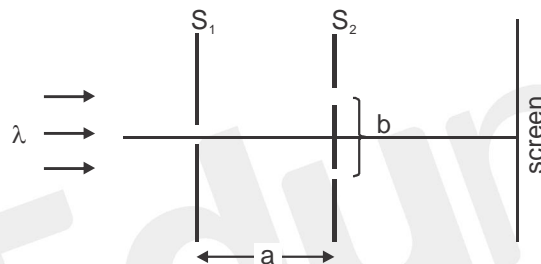

If the wavelength of the light is λ , the value of d for which the screen would be dark is

- (1) $b \sqrt{\left(\frac{a}{\lambda}\right)^2 - 1}$ (2) $\frac{b}{2} \sqrt{\left(\frac{a}{\lambda}\right)^2 - 1}$
 (3) $\frac{a}{2} \left(\frac{b}{\lambda}\right)^2$ (4) $\frac{ab}{\lambda}$

49. A constant current I is flowing in a piece of wire that is bent into a loop as shown in the figure.

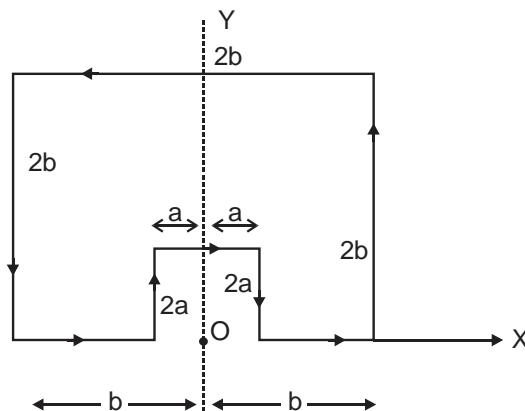

The magnitude of the magnetic field at the point O is

- (1) $\frac{\mu_0 I}{4\pi\sqrt{5}} \ln\left(\frac{a}{b}\right)$ (2) $\frac{\mu_0 I}{4\pi\sqrt{5}} \left(\frac{1}{a} - \frac{1}{b}\right)$
 (3) $\frac{\mu_0 I}{4\pi\sqrt{5}} \left(\frac{1}{a}\right)$ (4) $\frac{\mu_0 I}{4\pi\sqrt{5}} \left(\frac{1}{b}\right)$

50. Consider the potential

$$V(\vec{r}) = \sum_i V_0 a^3 \delta^{(3)}(\vec{r} - \vec{r}_i)$$

where \vec{r}_i are the position vectors of the vertices of a cube of length a centered at the origin and

V_0 is a constant. If $V_0 a^2 \ll \frac{\hbar^2}{m}$, the total scattering cross-section, in the low-energy limit, is

- (1) $16a^2 \left(\frac{mV_0 a^2}{\hbar^2}\right)$ (2) $\frac{16a^2}{\pi^2} \left(\frac{mV_0 a^2}{\hbar^2}\right)^2$
 (3) $\frac{64a^2}{\pi} \left(\frac{mV_0 a^2}{\hbar^2}\right)^2$ (4) $\frac{64a^2}{\pi^2} \left(\frac{mV_0 a^2}{\hbar^2}\right)^2$

51. The Green's function satisfying

$$\frac{d^2}{dx^2} g(x, x_0) = \delta(x - x_0)$$

where the boundary conditions $g(-L, x_0) = 0 = g(L, x_0)$, is

- (1) $\begin{cases} \frac{1}{2L}(x_0 - L)(x + L), & -L \leq x < x_0 \\ \frac{1}{2L}(x_0 + L)(x - L), & x_0 \leq x \leq L \end{cases}$ (2) $\begin{cases} \frac{1}{2L}(x_0 + L)(x + L), & -L \leq x < x_0 \\ \frac{1}{2L}(x_0 - L)(x - L), & x_0 \leq x \leq L \end{cases}$
 (3) $\begin{cases} \frac{1}{2L}(L - x_0)(x + L), & -L \leq x < x_0 \\ \frac{1}{2L}(x_0 + L)(L - x), & x_0 \leq x \leq L \end{cases}$ (4) $\frac{1}{2L}(x - L)(x + L), -L \leq x \leq L$

52. Let $\sigma_x, \sigma_y, \sigma_z$ be the Pauli matrices and $x'\sigma_x + y'\sigma_y + z'\sigma_z = \exp\left(\frac{i\theta\sigma_z}{2}\right) \times [x\sigma_x + y\sigma_y + z\sigma_z] \exp\left(-\frac{i\theta\sigma_z}{2}\right)$. Then the coordinates are related as follows

- (1) $\begin{pmatrix} x' \\ y' \\ z' \end{pmatrix} = \begin{pmatrix} \cos\theta & -\sin\theta & 0 \\ \sin\theta & \cos\theta & 0 \\ 0 & 0 & 1 \end{pmatrix} \begin{pmatrix} x \\ y \\ z \end{pmatrix}$ (2) $\begin{pmatrix} x' \\ y' \\ z' \end{pmatrix} = \begin{pmatrix} \cos\theta & \sin\theta & 0 \\ -\sin\theta & \cos\theta & 0 \\ 0 & 0 & 1 \end{pmatrix} \begin{pmatrix} x \\ y \\ z \end{pmatrix}$
 (3) $\begin{pmatrix} x' \\ y' \\ z' \end{pmatrix} = \begin{pmatrix} \cos\frac{\theta}{2} & \sin\frac{\theta}{2} & 0 \\ -\sin\frac{\theta}{2} & \cos\frac{\theta}{2} & 0 \\ 0 & 0 & 1 \end{pmatrix} \begin{pmatrix} x \\ y \\ z \end{pmatrix}$ (4) $\begin{pmatrix} x' \\ y' \\ z' \end{pmatrix} = \begin{pmatrix} \cos\frac{\theta}{2} & -\sin\frac{\theta}{2} & 0 \\ \sin\frac{\theta}{2} & \cos\frac{\theta}{2} & 0 \\ 0 & 0 & 1 \end{pmatrix} \begin{pmatrix} x \\ y \\ z \end{pmatrix}$

53. The interval $[0, 1]$ is divided into $2n$ parts of equal length to calculate the integral $\int_0^1 e^{i2\pi x} dx$ using Simpson's $\frac{1}{3}$ rule. What is the minimum value of n for the result to be exact ?
- (1) ∞ (2) 2
 (3) 3 (4) 4
54. Which of the following sets of 3×3 matrices (in which a and b are real numbers) form a group under matrix multiplication ?
- (1) $\left\{ \begin{pmatrix} 1 & 0 & a \\ 0 & 1 & 0 \\ b & 0 & 1 \end{pmatrix}; a, b \in \mathbb{R} \right\}$ (2) $\left\{ \begin{pmatrix} 1 & a & 0 \\ 0 & 1 & b \\ 0 & 0 & 1 \end{pmatrix}; a, b \in \mathbb{R} \right\}$
- (3) $\left\{ \begin{pmatrix} 1 & 0 & a \\ 0 & 1 & b \\ 0 & 0 & 1 \end{pmatrix}; a, b \in \mathbb{R} \right\}$ (4) $\left\{ \begin{pmatrix} 1 & a & 0 \\ b & 1 & 0 \\ 0 & 0 & 1 \end{pmatrix}; a, b \in \mathbb{R} \right\}$
55. The Lagrangian of a free relativistic particle (in one dimension) of mass m is given by $L = -m\sqrt{1 - \dot{x}^2}$ where $\dot{x} = dx/dt$. If such a particle is acted upon by a constant force in the direction of its motion, the phase space trajectories obtained from the corresponding Hamiltonian are
- (1) ellipses (2) cycloids
 (3) hyperbolas (4) parabolas
56. A Hamiltonian system is described by the canonical coordinate q and canonical momentum p . A new coordinate Q is defined as $Q(t) = q(t + \tau) + p(t + \tau)$, where t is the time and τ is a constant, that is, the new coordinate is a combination of the old coordinate and momentum at a shifted time. The new canonical momentum $P(t)$ can be expressed as
- (1) $p(t + \tau) - q(t + \tau)$ (2) $p(t + \tau) - q(t - \tau)$
 (3) $\frac{1}{2}[p(t - \tau) - q(t + \tau)]$ (4) $\frac{1}{2}[p(t + \tau) - q(t + \tau)]$
57. The single particle energy levels of a non-interacting three-dimensional isotopic system, labelled by momentum k , are proportional to k^3 . The ratio \bar{P}/ϵ of the average pressure \bar{P} to the energy density ϵ at a fixed temperature, is
- (1) $\frac{1}{3}$ (2) $\frac{2}{3}$
 (3) 1 (4) 3
58. The Hamiltonian for three Ising spins S_0, S_1 and S_2 , taking values ± 1 is
- $$H = -JS_0(S_1 + S_2)$$
- If the system is in equilibrium at temperature T , the average energy of the system, in terms of $\beta = (k_B T)^{-1}$, is
- (1) $-\frac{1 + \cosh(2\beta J)}{2\beta \sinh(2\beta J)}$ (2) $-2J[1 + \cosh(2\beta J)]$
 (1) $-2/\beta$ (4) $-2J \frac{\sin(2\beta J)}{2 + \cosh(2\beta J)}$

59. Let I_0 be the saturation current, η the ideality factor and v_F and v_R the forward and reverse potentials, respectively, for a diode. The ratio R_R/R_F of its reverse and forward resistances R_R and R_F respectively, varies as (In the following k_B is the Boltzmann constant, T is the absolute temperature and q is the charge.)

(1) $\frac{v_R}{v_F} \exp\left(\frac{qv_F}{\eta k_B T}\right)$

(2) $\frac{v_F}{v_R} \exp\left(\frac{qv_F}{\eta k_B T}\right)$

(3) $\frac{v_R}{v_F} \exp\left(-\frac{qv_F}{\eta k_B T}\right)$

(4) $\frac{v_F}{v_R} \exp\left(-\frac{qv_F}{\eta k_B T}\right)$

60. The Coulomb potential $V(r) = -e^2/r$ of a hydrogen atom is perturbed by adding $H' = bx^2$ (where b is a constant) to the Hamiltonian. The first order correction to the ground state energy is (The

ground state wavefunction is $\psi_0 = \frac{1}{\sqrt{\pi a_0^3}} e^{-r/a_0}$).

(1) $2ba_0^2$

(2) ba_0^2

(3) $b a_0^2 / 2$

(4) $\sqrt{2} b a_0^2$

61. Using the trial function

$$\psi(x) = \begin{cases} A(a^2 - x^2), & -a < x < a \\ 0 & \text{otherwise} \end{cases}$$

the ground state energy of a one-dimensional harmonic oscillator is

(1) $\hbar\omega$

(2) $\sqrt{\frac{5}{14}} \hbar\omega$

(3) $\frac{1}{2} \hbar\omega$

(4) $\sqrt{\frac{5}{7}} \hbar\omega$

62. In the usual notation $|n l m\rangle$ for the states of a hydrogen like atom, consider the spontaneous transitions $|2 1 0\rangle \rightarrow |1 0 0\rangle$ and $|3 1 0\rangle \rightarrow |1 0 0\rangle$. If t_1 and t_2 are the lifetimes of the first and

the second decaying states respectively, then the ratio $\frac{t_1}{t_2}$ is proportional to

(1) $\left(\frac{32}{27}\right)^3$

(2) $\left(\frac{27}{32}\right)^3$

(3) $\left(\frac{2}{3}\right)^3$

(4) $\left(\frac{3}{2}\right)^3$

63. A random variable n obeys Poisson statistics. The probability of finding $n = 0$ is 10^{-6} . The expectation value of n is nearest to

(1) 14

(2) 10^6

(3) e

(4) 10^2

64. In the following operational amplifier circuit $C_{in} = 10 \text{ nF}$, $R_{in} = 20 \text{ k}\Omega$, $R_F = 200 \text{ k}\Omega$ and $C_F = 100 \text{ pF}$.

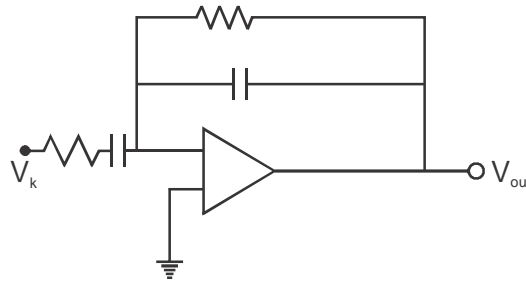

The magnitude of the gain at a point signal frequency of 16 kHz is

- (1) 67 (2) 0.15
 (3) 0.3 (4) 3.5
65. Both the data points and a linear fit to the current vs voltage of a resistor are shown in the graph below.

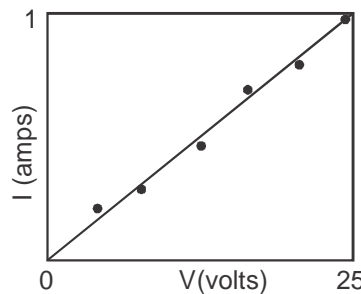

If the error in the slope is $1.255 \times 10^{-3} \Omega^{-1}$, then the value of resistance estimated from the graph is

- (1) $(0.04 \pm 0.8) \Omega$ (2) $(25.0 \pm 0.8) \Omega$
 (3) $(25 \pm 1.25) \Omega$ (4) $(25 \pm 0.0125) \Omega$
66. In the figures below, X and Y are one bit inputs. The circuit which corresponds to a one bit comparator is

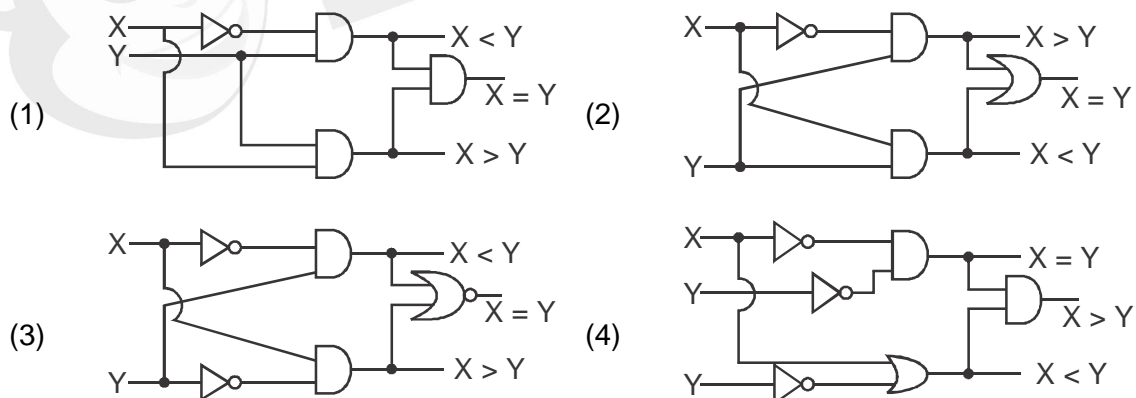

67. If in a spontaneous α -decay of ${}^{232}_{92}\text{U}$ at rest, the total energy released in the reaction is Q, then the energy carried by the α -particle is
- (1) $57Q/58$ (2) $Q/57$
 (3) $Q/58$ (4) $23Q/58$

68. The range of the nuclear force between two nucleons due to the exchange of pion is 1.40 fm. If the mass of the pion is $140 \text{ MeV}/c^2$ and the mass of the rho-meson is $770 \text{ MeV}/c^2$, then the range of the force due to exchange of rho-mesons is
- (1) 1.40 fm (2) 7.70 fm
 (3) 0.25 fm (4) 0.18 fm
69. A baryon X decays by strong interaction as $X \rightarrow \Sigma^+ + \pi^- + \pi^0$, where Σ^+ is a member of the isotriplet (Σ^+ , Σ^0 , Σ^-). The third component I_3 of the isospin of X is
- (1) 0 (2) 1/2
 (3) 1 (4) 3/2
70. The energy gap and lattice constant of an indirect band gap semiconductor are 1.875 eV 0.52 nm, respectively. For simplicity take the dielectric constant of the material to be unity. When it is excited by broadband radiation, an electron initially in the valence band at $k = 0$ makes a transition to the conduction band. The wavevector of the electron in the conduction band, in terms of the wavevector k_{max} at the edge of the Brillouin zone, after the transition is closer to
- (1) $k_{\text{max}}/10$ (2) $k_{\text{max}}/100$
 (3) $k_{\text{max}}/1000$ (4) 0
71. The electrical conductivity of copper is approximately 95% of the electrical conductivity of silver, while the electron density in silver is approximately 70% of the electron density in copper. In Drude's model, the approximate ratio $\tau_{\text{Cu}}/\tau_{\text{Ag}}$ of the mean collision time in copper (τ_{Cu}) to the mean collision in silver (τ_{Ag}) is
- (1) 0.44 (2) 1.50
 (3) 0.33 (4) 0.66
72. The charge distribution inside a material of conductivity σ and permittivity ϵ at initial time $t = 0$ is $\rho(r, 0) = \rho_0$, a constant. At subsequent times $\rho(r, t)$ is given by
- (1) $\rho_0 \exp\left(-\frac{\sigma t}{\epsilon}\right)$ (2) $\frac{1}{2}\rho_0 \left[1 + \exp\left(\frac{\sigma t}{\epsilon}\right)\right]$
 (3) $\frac{\rho_0}{\left[1 - \exp\left(\frac{\sigma t}{\epsilon}\right)\right]}$ (4) $\rho_0 \cos \frac{\sigma t}{\epsilon}$
73. An atomic spectral line is observed to split into nine components due to Zeeman shift. If the upper state of the atom is 3D_2 then the lower state will be
- (1) 3F_2 (2) 3F_1
 (3) 3P_1 (4) 3P_2
74. If the coefficient of stimulated emission for a particular transition is $2.1 \times 10^{19} \text{ m}^3 \text{ W}^{-1} \text{ s}^{-3}$ and the emitted photon is at wavelength 3000 Å, then the lifetime of the excited state is approximately
- (1) 20 ns (2) 40 ns
 (3) 80 ns (4) 100 ns

75. If the binding energies of the electron in the K and L shells of silver atom are 25.4 keV and 3.34 keV, respectively, then the kinetic energy of the Auger electron will be approximately
- | | |
|--------------|--------------|
| (1) 22 keV | (2) 9.3 keV |
| (3) 10.5 keV | (4) 18.7 keV |



ANSWER KEY

1	2	3	4	5	6	7	8	9	10
2	2	1	2	2	3	1	1	3	3
11	12	13	14	15	16	17	18	19	20
1	1	2	3	3	4	1	3	1	3
21	22	23	24	25	26	27	28	29	30
4	3	2	4	3	1	1	3	1	3
31	32	33	34	35	36	37	38	39	40
3	4	4	3	2	1	2	4	2	1
41	42	43	44	45	46	47	48	49	50
1	3	2	3	4	2	4	2	2	3
51	52	53	54	55	56	57	58	59	60
1	2	2	3	3	4	3	4	1	2
61	62	63	64	65	66	67	68	69	70
2	1	1	3	2	3	1	3	1	3
71	72	73	74	75					
4	1	3	3	4					

